

Machining Center Angle Heads

**standard
size 3**

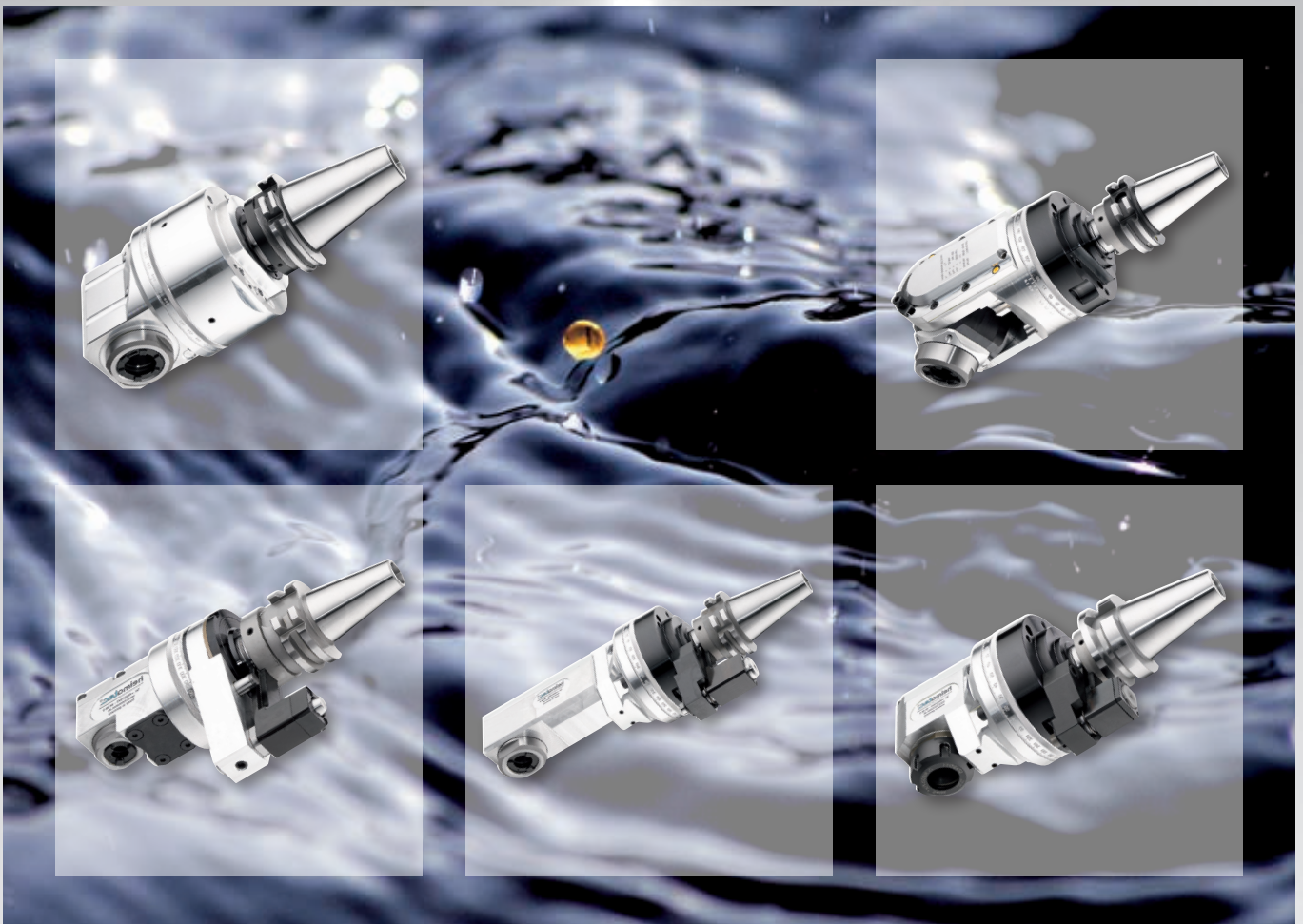



Terms and conditions:

You will find them on our website

www.heimatec.com

Home/Imprint/Terms and Conditions

This catalogue, including all its parts, is protected by copyright. Each use outside the restricted limitations of the Copyright Act is inadmissible and liable to prosecution without the consent of heimatec. This is particularly valid for duplication, translation, microfilming and feeding and processing in electronic systems.

heimatec® GmbH reserves the right of technical changes everytime without advance notice, which is particularly valid for adaptations to new or changed international standards, or to developments of our products or manufacturing processes.

► **Angle Heads line standard**

Adaptable for various application



► **Angle Heads ; standard**
360° turnable

For machining tasks without geometric constraints.

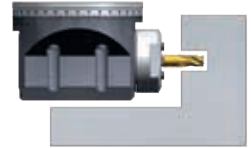

► **Angle Heads ; double spindle**
360° turnable

For machining tasks without geometric constraints and to manufacture in the opposite direction.

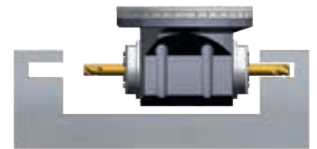

► **Angle Heads ; standard ; offset**
360° turnable

For machining tasks with geometric constraints. Offset output to maximize the usable tool length.

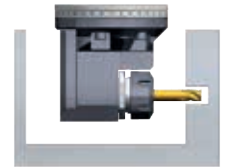

► **Angle Heads ; offset ; slim**
360° turnable

For special machining tasks with strong geometric constraints which need special plunging. Offset output to maximize the usable tool length.



► **Angle Heads ; ± 90° adjustable**
360° turnable

For machining tasks which enable the changing and angular position of the tool.



► features and overview

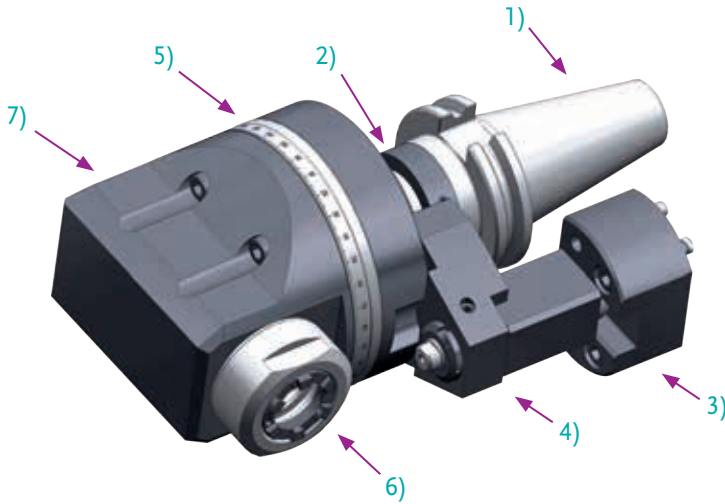

- 1) **Machine adaption**
DIN 69871 A - SK
DIN 69893 - HSK
MAS 403 BT
ANSI B 5.50/ CAT
- 2) **Arrestor ring**
Locks the tool drive taper.
- 3) **Stop block**
For locking and preventing the rotation of the angle head.
Optional machine specification according customer's instruction.
- 4) **Torque arm**
For locking the housing of the angle head on the machining spindle to prevent the rotation of the angle head.
- 5) **Scale ring**
Controllable and continuous rotation of the tool ensures the ideal working angle.
- 6) **Tooladaption**
The standard tooladaptions are equipped with collet chucks.
- 7) **Housing**
45/90° angle possibilities, depending on the required use

► combinations

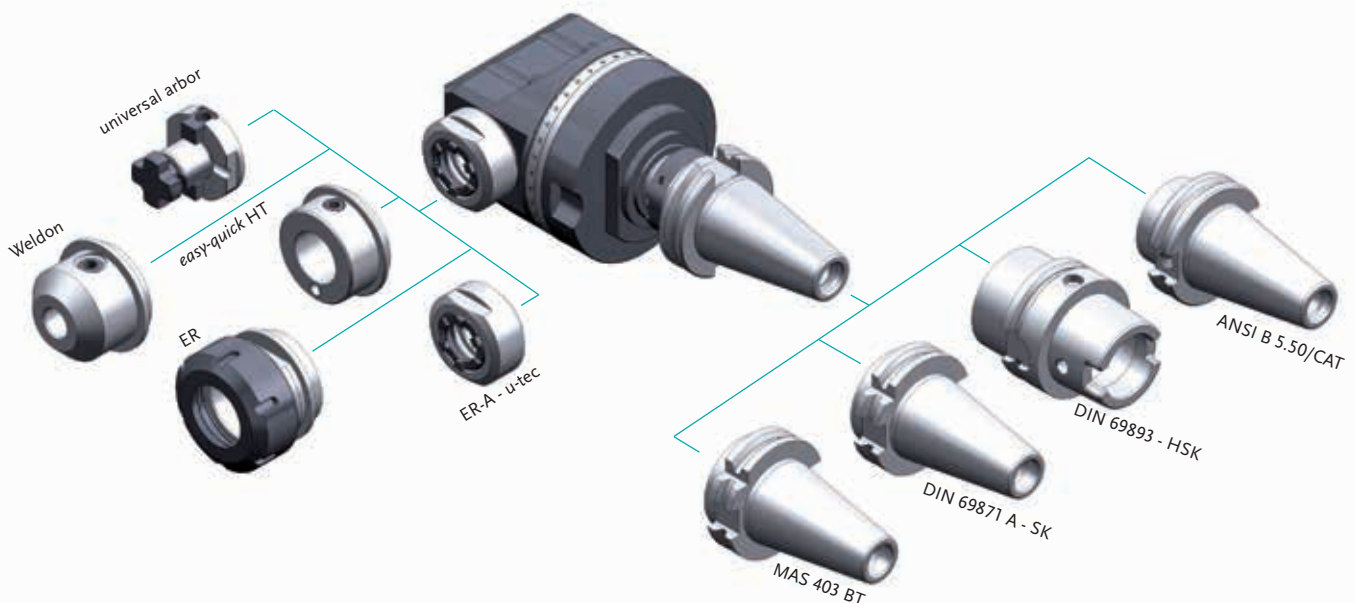

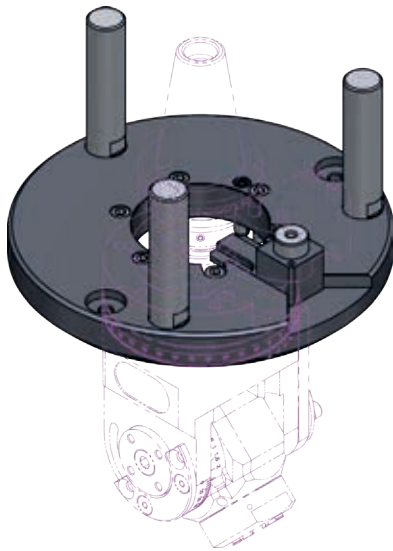

► **Support flange with integrated torque arm**

For additional support, in order to stabilize and to reduce the vibration of the entire system. The additional support will be produced specifically according to customer's instruction and the machine specifications.

► **Torque arm**

Locates the angle head at the machining spindle and secures/prevent the rotation of the angle head. Optional machine specification according customer's instruction.

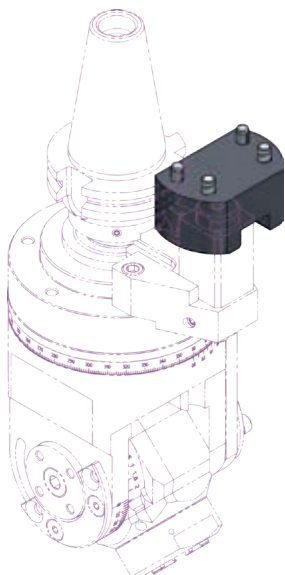
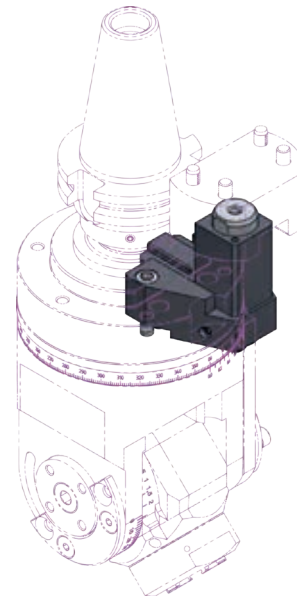

► **Stop block**

For locking and preventing the rotation of the angle head. Optional machine specification according customer's instruction.

► Angle Heads

360° turnable

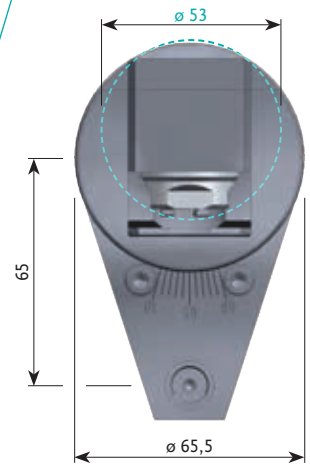
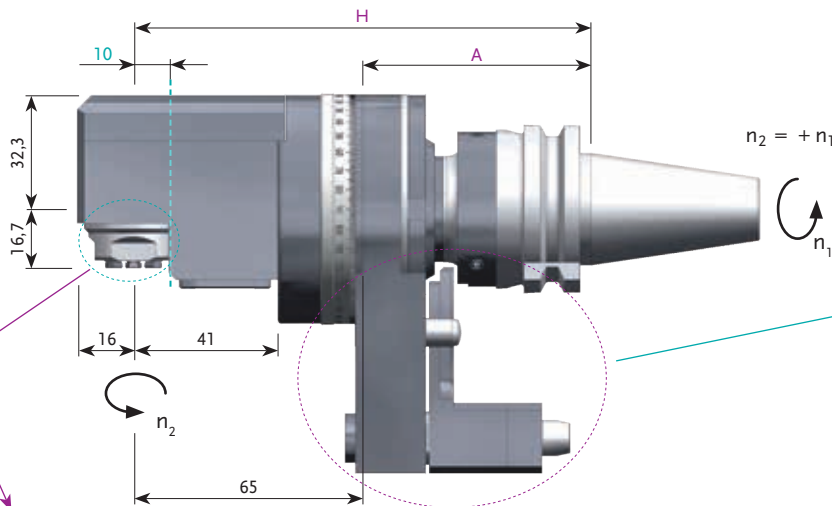
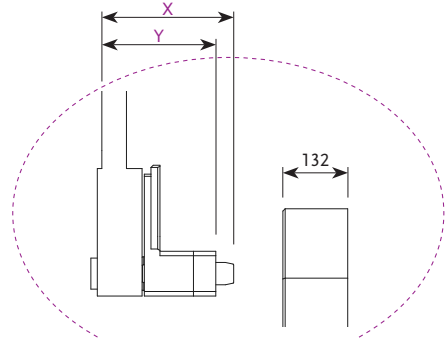
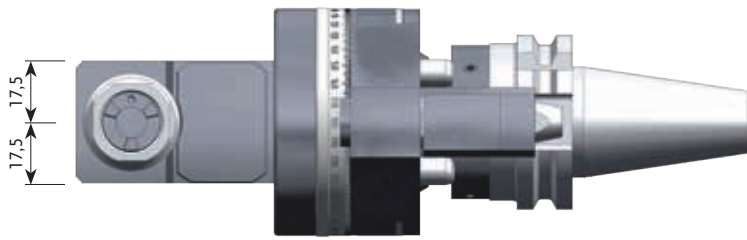







size 3 offset



tool adaption : **ER 11 A** ($\varnothing 0,5 - \varnothing 7,0$)
 rotation $n_{2 \max}$ [1/min] : 8000
 torque $M_{2 \max}$ [Nm] : 6

coolant : no
 gear ratio [i] : 1:1
 rotating direction : same

ref.-no.	machine adaption	center distance H [mm]	gauge line of housing A [mm]	torque arm		stop-block
				Dim. X [mm]	Dim. Y [mm]	
7 033 23 002	 DIN 69871 A - SK 30	130	65		59	51
7 033 23 001				✓	59	51
7 033 23 000				✗	-	-
7 033 33 002	 DIN 69893 - HSK 40 A	138	73		59	51
7 033 33 001				✓	59	51
7 033 33 000				✗	-	-
7 033 23 005	 MAS 403 BT 30	130	65		59	51
7 033 23 004				✓	59	51
7 033 23 003				✗	-	-

note: support optional!

✗ = not included in delivery
 ✓ = included in delivery
 Dim. X = end face fixing bolt / gauge line of the housing
 Dim. Y = locking device / gauge line of the housing

► further versions on request





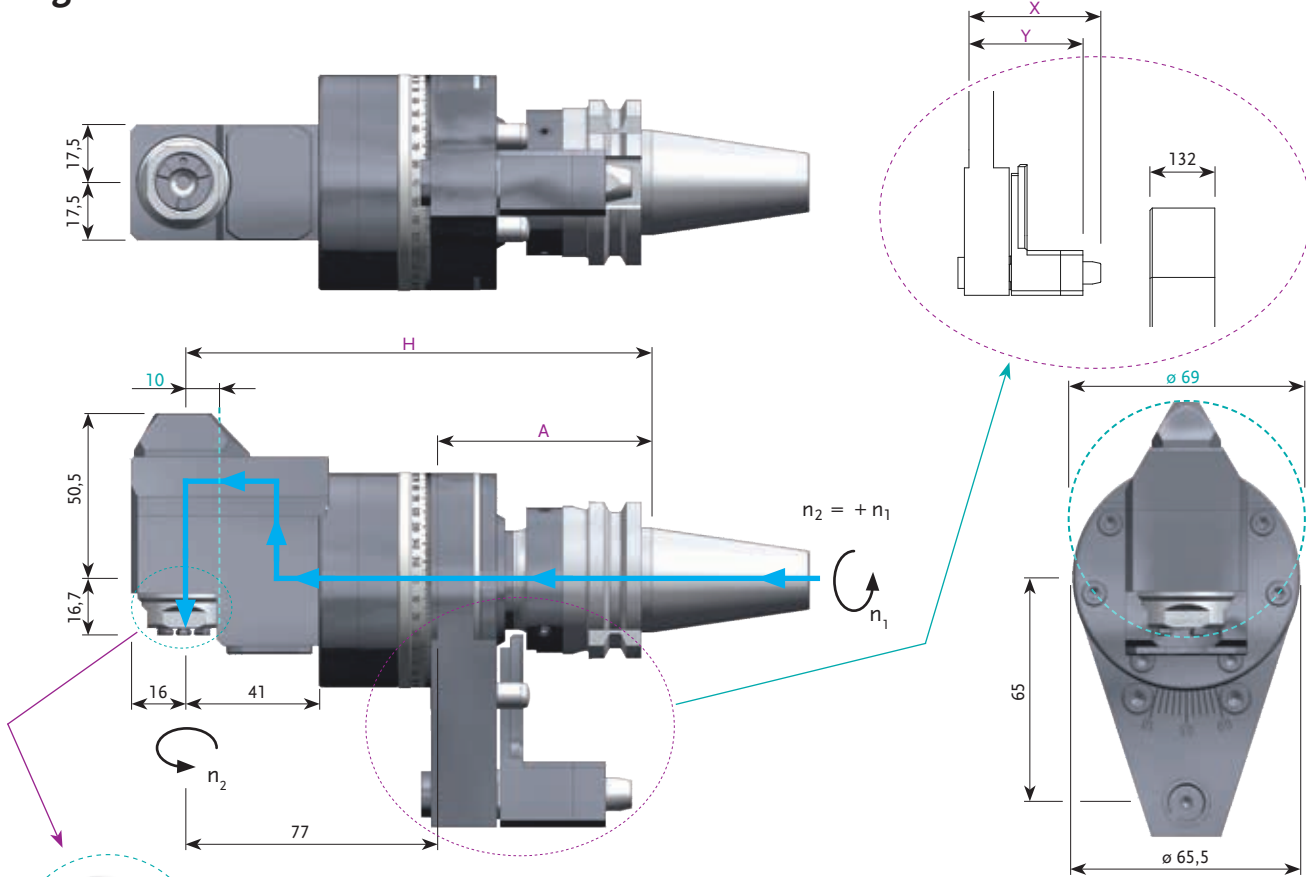

















► Angle Heads

360° turnable



tool adaption : ER 11 A (ø0,5 - ø7,0)
rotation $n_{2 \max}$ [1/min] : 8000
torque $M_{2 \max}$ [Nm] : 6

← coolant : IK 70 [bar] — gear ratio [i] : 1:1
rotating direction : same

ref.-no.	machine adaption	center distance H [mm]	gauge line of housing A [mm]	torque arm		stop-block	
					Dim. X [mm]		Dim. Y [mm]
7 033 23 008	 DIN 69871 A - SK 30	142	65		59	51	
7 033 23 007					59	51	
7 033 23 006					-	-	
7 033 33 005	 DIN 69893 - HSK 40 A	150	73		59	51	
7 033 33 004					59	51	
7 033 33 003					-	-	
7 033 23 011	 MAS 403 BT 30	142	65		59	51	
7 033 23 010					59	51	
7 033 23 009					-	-	

note: support optional!

* = not included in delivery
✓ = included in delivery
Dim. X = end face fixing bolt / gauge line of the housing
Dim. Y = locking device / gauge line of the housing

► further versions on request





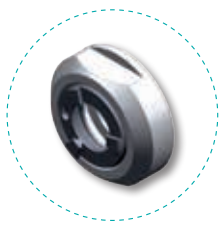
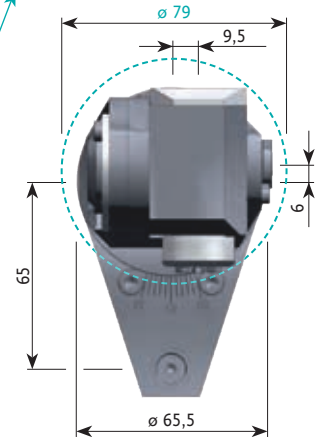
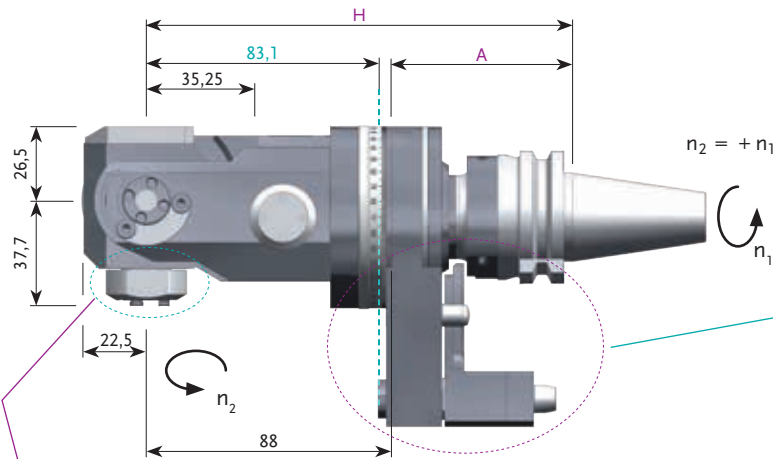
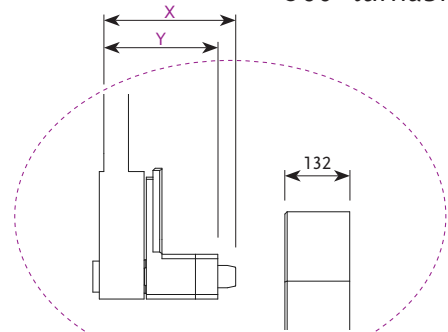



► Angle Heads + 90°

360° turnable



tool adaption : ER 11 A (ø0,5 - ø7,0)
 rotation $n_{2 \max}$ [1/min] : 8000
 torque $M_{2 \max}$ [Nm] : 5

coolant : no
 gear ratio [i] : 1:1
 rotating direction : same

ref.-no.	machine adaption	center distance H [mm]	gauge line of housing A [mm]	torque arm		stop-block	
				Dim. X [mm]	Dim. Y [mm]		
7 043 23 008	 DIN 69871 A - SK 30	153	65		59	51	
7 043 23 007				✓	59	51	✗
7 043 23 006				✗	-	-	✗
7 043 33 002	 DIN 69893 - HSK 40 A	161	73		59	51	
7 043 33 001				✓	59	51	✗
7 043 33 000				✗	-	-	✗
7 043 23 003	 MAS 403 BT 30	153	65		59	51	
7 043 23 000				✓	59	51	✗
7 043 23 002				✗	-	-	✗

note: support optional!









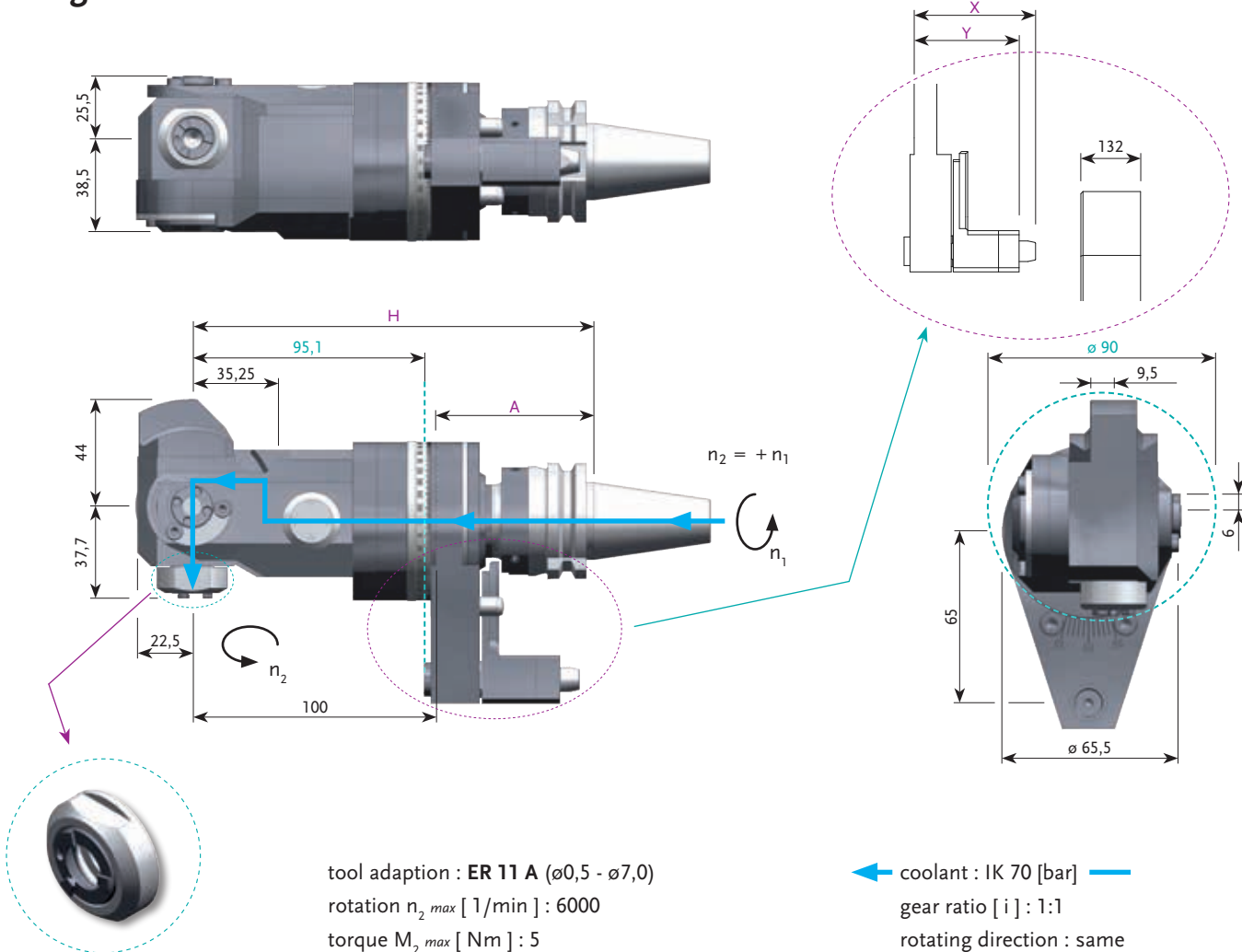













✗ = not included in delivery
 ✓ = included in delivery
 Dim. X = end face fixing bolt / gauge line of the housing
 Dim. Y = locking device / gauge line of the housing

► further versions on request

► Angle Heads + 90°

360° turnable



ref.-no.	machine adaption	center distance H [mm]	gauge line of housing A [mm]	torque arm		stop-block	
					Dim. X [mm]		Dim. Y [mm]
7 043 23 011	 DIN 69871 A - SK 30	165	65		59	51	
7 043 23 010					59	51	
7 043 23 009					-	-	
7 043 33 005	 DIN 69893 - HSK 40 A	173	73		59	51	
7 043 33 004					59	51	
7 043 33 003					-	-	
7 043 23 005	 MAS 403 BT 30	165	65		59	51	
7 043 23 001					59	51	
7 043 23 004					-	-	

note: support optional!

* = not included in delivery
✓ = included in delivery
Dim. X = end face fixing bolt / gauge line of the housing
Dim. Y = locking device / gauge line of the housing

► further versions on request

7 040 45 007
Angle Head
± 90° adjustable
ER 25 AX - u-tec



7 033 45 021
Angle Head
offset
ER 25



7 037 86 000
Disk Mill Head
arbor 27



7 033 23 001
Angle Head
offset
ER 11 A



7 039 64 000
Angle Head
double spindle
arbor 16



7 030 66 010
Angle Head
ER 32 AX - u-tec



7 050 54 003
Multi Spindle Drilling Head
6 - spindle
ER 16 M



7 030 41 064
Angle Head
RA - 100
CH8



7 039 41 017
Angle Head
KC - 300
CHC



7 030 41 061
Angle Head
MFC - 300 S
K252



► **easy-quick HT fast change system**

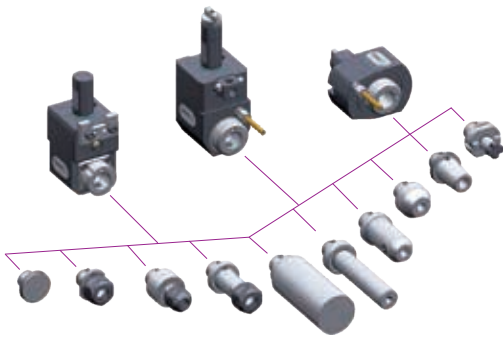

THE fast change system of heimatec
for driven and static tools

► versions see catalogue



www.heimatec.com
products / easy-quick

► **u-tec[®] UT change system**

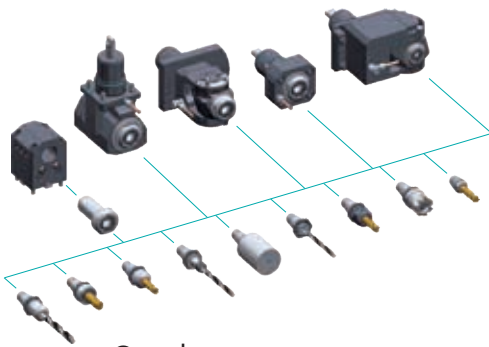

Our change system,
that makes EVERYTHING possible

► versions see catalogue



www.heimatec.com
products / u-tec

► **accessories**



► versions see catalogue

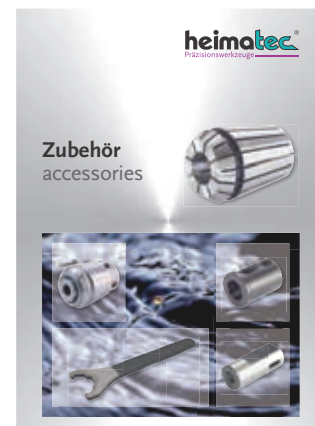

www.heimatec.com
products / accessories

heimatec®

● heimatec® - overseas branches

● global representations of heimatec®



headquarters

heimatec® GmbH
Präzisionswerkzeuge
Carl-Benz-Straße 4
D- 77871 Renchen
Postfach 11 36
D- 77867 Renchen

Tel.: +49 (78 43) 94 66 0
Fax: +49 (78 43) 94 66 66
heimatec.de
info@heimatec.de

heimatec® Inc.
USA
usa.heimatec.com
USA@heimatec.com

heimatec®-Ost, JSC
Russia
ru.heimatec.com
Russia@heimatec.com

heimatec® Ltd.
Taiwan
tw.heimatec.com
Taiwan@heimatec.com

heimatec®
Singapore
sg.heimatec.com
Singapore@heimatec.com

heimatec® India Pvt Ltd.
India
in.heimatec.com
India@heimatec.com

